

## Logic Circuits

The digital system consists of two types of circuits, namely

- 1- Combinational Logic Circuits.
- 2- Sequential Logic Circuits.

### 1- Combinational Logic Circuits:

A combinational circuit consists of logic gates whose outputs at any time are determined from only the present combination of inputs without regard to previous inputs or previous state of outputs. The design of Combinational logic circuit depending on the derivation of the Boolean expression from the truth table base on **sum of product** or **product of sum**.

### Design Procedures using POS are :-

- 1- Write the truth table for all input states which equal to  $(2^n)$  where n is the number of inputs.
- 2- Write the expression for each (Logic 0) output with OR gate
- 3- Write the overall output expression by AND ing the terms in step 2 and if it is possible Simplify this expression.
- 4- Implement this expression using logic gates

Example : Derive the Boolean expression from the following truth table using POS and draw the logic diagram.

Inputs		Output
B	A	Y
0	0	1
0	1	0
1	0	1
1	1	1

Sol:  $Y = \bar{A} + B$

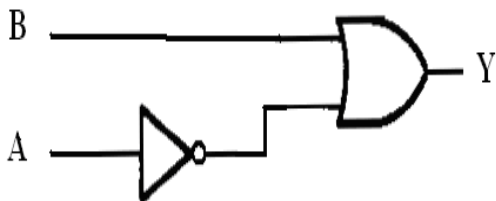

**Design Procedures using SOP are :-**

- 1- Write the truth table for all input states which equal to ( $2^n$ ) where n is the number of inputs.
- 2- Write the expression for each (Logic 1) output with AND gate
- 3- Write the overall output expression by OR ing the terms in step 2 and if it is possible Simplify this expression.
- 4- Implement this expression using logic gates

Example: Design a logic circuit that has 3 inputs and gives a (logic 1) output when the binary input value less than or equal 2.

**Sol:** number of inputs =3 ; number of states =  $2^3 = 8$

Inputs			Output
C	B	A	Y
0	0	0	1
0	0	1	1
0	1	0	1
0	1	1	0
1	0	0	0
1	0	1	0
1	1	0	0
1	1	1	0

$$Y = \bar{A}\bar{B}\bar{C} + \bar{A}\bar{B}C + \bar{A}B\bar{C}$$

$$Y = \bar{B}\bar{C}(\bar{A} + A) + \bar{A}B\bar{C}$$

$$Y = \bar{B}\bar{C} + \bar{A}B\bar{C}$$

$$Y = \bar{C}(\bar{B} + \bar{A}B)$$

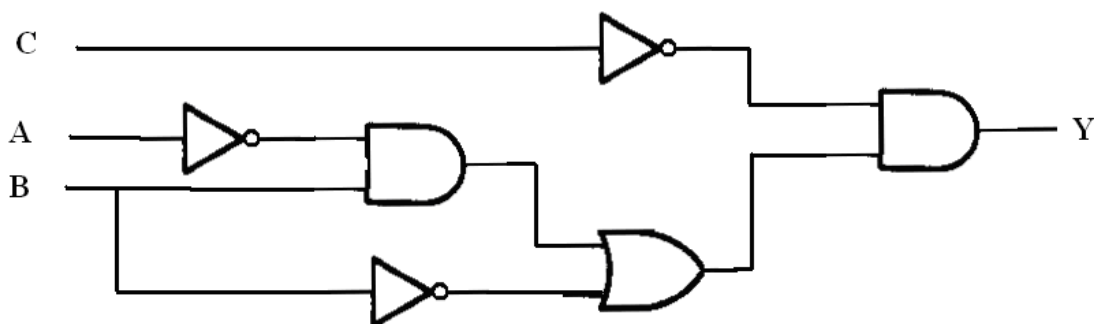

## Common Functions of Combinational Logic

There are many combinational logic circuits or diagrams commonly used in all logic systems such as:

- 1- Adders & Subtractors
- 2- Magnitude Comparators
- 3- Multiplexer and demultiplexers
- 4- Decoders and Encoders

## Adders

Arithmetic operations are among the basic functions of a digital computer. Addition of two binary digits is the most basic arithmetic operation. The simple addition consists of four possible elementary operations, which are  $0+0 = 0$ ,  $0+1 = 1$ ,  $1+0 = 1$ , and  $1+1 = 0$  with carry one. The two types of adders are :-

a) Half adder ( HA ) :

A half adder is a multiple outputs combinational logic circuit which add two bits of binary data **without carry**, producing a sum ( S ) and a carry out ( Co ).

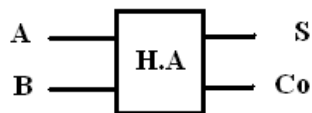

Symbol of half adder (H.A )

B	A	S	Co
0	0	0	0
0	1	1	0
1	0	1	0
1	1	0	1

Truth Table of half adder (H.A )

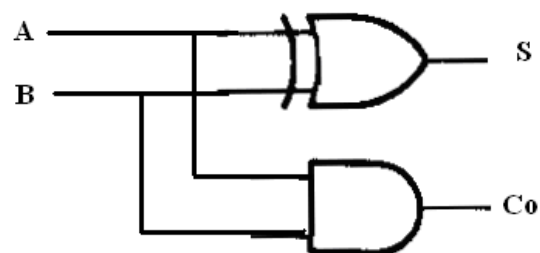

Circuit diagram of half adder (H.A )

$$S = \bar{B}A + B\bar{A}$$

$$S = A \oplus B$$

$$C_o = AB$$

**b) Full adder ( FA ) :**

A full adder is a multiple outputs combinational logic circuit which add two bits of binary data **with carry input ( C<sub>i</sub> )**, producing a sum (S) and a carry out (C<sub>o</sub>).

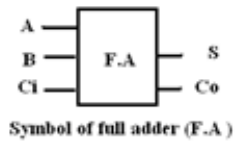

C <sub>i</sub>	B	A	S	C <sub>o</sub>
0	0	0	0	0
0	0	1	1	0
0	1	0	1	0
0	1	1	0	1
1	0	0	1	0
1	0	1	0	1
1	1	0	0	1
1	1	1	1	1

Truth Table of full adder (F.A)

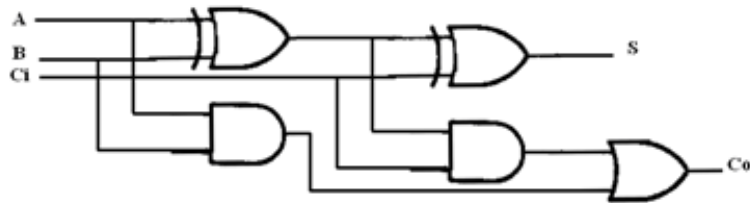

Circuit diagram of full adder (F.A)

$$S = A\bar{B}\bar{C}_i + \bar{A}B\bar{C}_i + \bar{A}\bar{B}C_i + ABC_i$$

$$S = \bar{C}_i(A\bar{B} + \bar{A}B) + C_i(\bar{A}\bar{B} + AB)$$

$$S = \bar{C}_i(A \oplus B) + C_i(\overline{A \oplus B})$$

$$S = A \oplus B \oplus C_i$$

$$C_o = A\bar{B}\bar{C}_i + \bar{A}B\bar{C}_i + \bar{A}\bar{B}C_i + ABC_i$$

$$C_o = AB(\bar{C}_i + C_i) + (\bar{A}\bar{B} + \bar{A}B)C_i$$

$$C_o = AB + (A \oplus B)C_i$$

**Parallel adder :**

How can we add two binary numbers of 4 bits

N	A3	A2	A1	A0	
M	B3	B2	B1	B0	+
S	S4	S3	S2	S1	S0

We need 3 full adders and 1 half adder

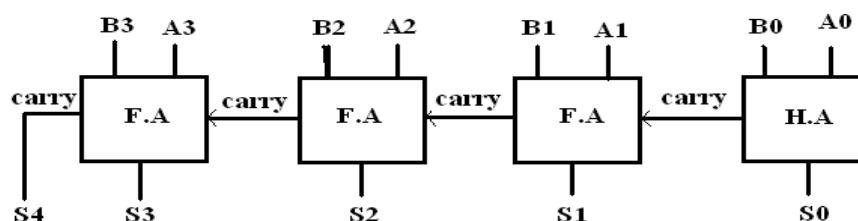

## Subtractors

Subtraction is the other basic function of arithmetic operations of information-processing tasks of digital computers. Similar to the addition function, subtraction of two binary digits consists of four possible elementary operations, which are  $0-0 = 0$ ,  $0-1 = 1$  with borrow of 1,  $1-0 = 1$ , and  $1-1 = 0$ . There are two types of subtractor

### a) Half Subtractor

A half-subtractor has two inputs and two outputs. Let the input be designated as X and Y respectively, and output functions be designated as D for difference and B for borrow. The truth table of the function X-Y is as follows

Input variables		Output variables	
X	Y	D	B
0	0	0	0
0	1	1	1
1	0	1	0
1	1	0	0

$$D = \bar{X}Y + X\bar{Y}$$

$$D = X \oplus Y$$

$$B = \bar{X}Y$$

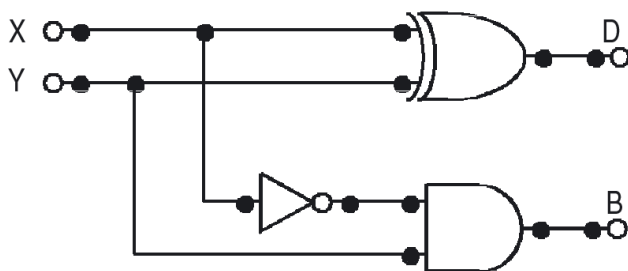

## b) Full Subtractor

A combinational circuit of full-subtractor performs the operation of subtraction of three bits—the minuend, subtrahend, and borrow generated from the subtraction operation of previous significant digits and produces the outputs difference and borrow. Let us designate the input variables minuend as X, subtrahend as Y, and previous borrow as Z, and outputs difference as D and borrow as B. Eight different input combinations are possible for three input variables. The truth table of X- Y is shown below

Input variables			Outputs	
X	Y	Z	D	B
0	0	0	0	0
0	0	1	1	1
0	1	0	1	1
0	1	1	0	1
1	0	0	1	0
1	0	1	0	0
1	1	0	0	0
1	1	1	1	1

$$\begin{aligned}
 D &= \bar{X}\bar{Y}Z + \bar{X}Y\bar{Z} + X\bar{Y}\bar{Z} + XYZ \\
 D &= \bar{Z}(\bar{X}Y + X\bar{Y}) + Z(\bar{X}\bar{Y} + XY) \\
 D &= \bar{Z}(X \oplus Y) + Z\overline{(X \oplus Y)} \\
 D &= X \oplus Y \oplus Z
 \end{aligned}$$

$$\begin{aligned}
 B &= \bar{X}\bar{Y}Z + \bar{X}Y\bar{Z} + \bar{X}YZ + XYZ \\
 B &= \bar{X}Y(\bar{Z} + Z) + Z(\bar{X}\bar{Y} + XY) \\
 B &= \bar{X}Y + Z\overline{(X \oplus Y)}
 \end{aligned}$$

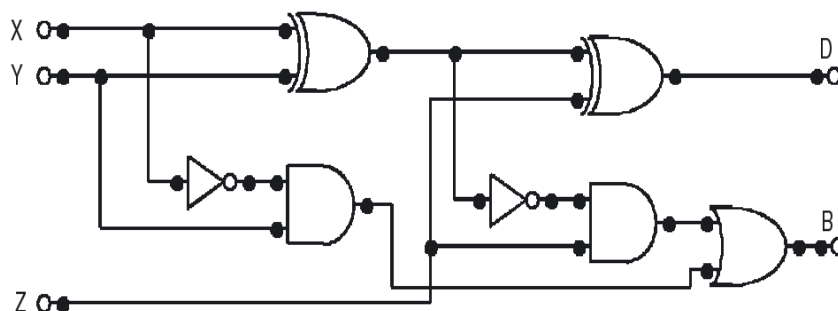

## Magnitude Comparator

A *magnitude comparator* is one of the useful combinational logic networks and has wide applications. It compares two binary numbers and determines if one number is greater than, less than, or equal to the other number. It is a multiple output combinational logic circuit. If two binary numbers are considered as A and B, the magnitude comparator gives three outputs for  $A > B$ ,  $A < B$ , and  $A = B$ .

Input variables		Output Variables		
A	B	A=B	A>B	A<B
0	0	1	0	0
0	1	0	0	1
1	0	0	1	0
1	1	1	0	0

$$(A = B) = \overline{A}B + A\overline{B} = \overline{(A \oplus B)}$$

$$(A > B) = A\overline{B}$$

$$(A < B) = \overline{A}B$$

